

Encounter Data System User Group

April 4, 2013

Agenda

- Purpose
- Session Guidelines
- CMS Updates
- EDS Updates
 - EDS Known Issues
 - EDS Edit(s)
- EDS Operational Error Prevention Strategies
- PACE Services
- Guidance for New 2013 MAOs and Other Entities
 - Error Reconciliation for Acknowledgement Reports
- EDS Companion Guides
- EDS Implementation Next Steps
- Closing Remarks

Purpose

- To provide Medicare Advantage Organizations (MAOs) and other entities that are currently submitting encounter data with operational guidance on testing and submitting production data to the Encounter Data System (EDS).
- To provide new 2013 MAOs and other entities with resources and operational guidance related to certification and submission of encounter data to the EDS.
- To provide Medicare Advantage Organizations (MAOs) and other entities information on EDS policy.

MAOs and Other Entities

- CMS requires the following types of organizations to submit encounter data:
 - Medicare Advantage (MA) Plans
 - Medicare Advantage-Prescription Drug (MA-PD) Plans
 - Health Maintenance Organizations (HMOs)
 - Special Needs Plans (SNPs)
 - Local Preferred Provider Organizations (PPOs)
 - Regional PPOs
 - Employer Group Health Plans
 - Programs of All-Inclusive Care for the Elderly (PACE) Plans
 - Cost Plans (1876 Cost HMOs/CMPs and 1833 HCPPs)
 - Medical Savings Account (MSA) Plans
 - Private Fee-for-Service (PFFS) Plans
 - Religious Fraternal Benefit (RFB) Plans
 - Provider Sponsored Organizations (PSOs)

Session Guidelines

- This is a one (1) hour Encounter Data User Group session.
- The first portion of this session will address updates for the EDS.
- The second portion of this session will address guidance for new 2013 MAOs and other entities.
- If time allows, the Encounter Data team will facilitate two (2) Q&A periods.

CMS Updates

2012 End-to-End Certification Status

- 549 MAOs and other entities

– **538 certified**

*Certification deadline:
August 31, 2012*

- 89 PACE Organizations

– **68 certified**

*Certification deadline:
February 28, 2013*

End-to-End Certification Status as of April 2, 2013

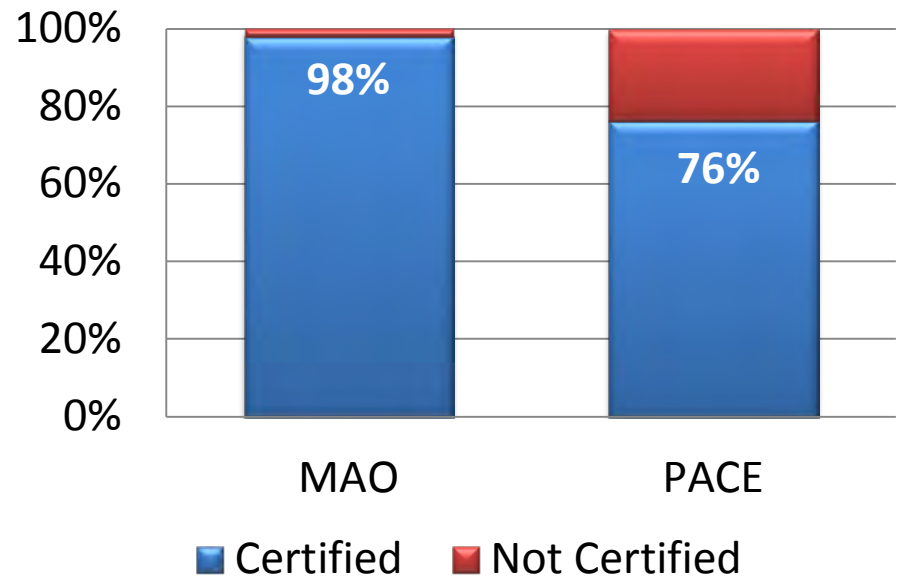

Note: Those submitters that do not meet the requirements for end-to-end certification will receive written communication.

End-to-End Certification Status for New 2013 MAOs and Other Entities

- 37 new MAOs and other entities
 - 34 certified
- 5 new PACE Organizations
 - 3 certified

End-to-End Certification Status as of April 2, 2013

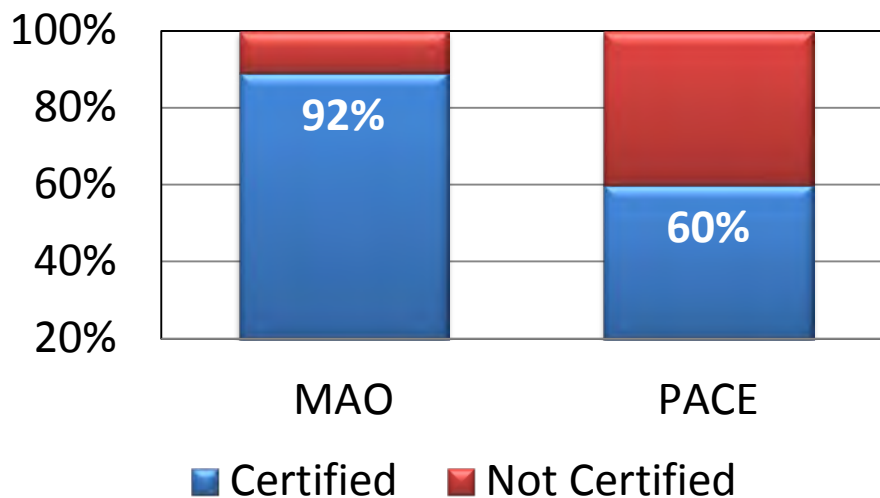

Note: MAOs and other entities that have not submitted EDI Agreements and Submitter Applications by February 15, 2013 are considered non-compliant.

MAO-002 Reports Update

- The EDPS is currently processing MAO-002 Reports for data received on March 27, 2013.
- If you have not received your MAO-002 Reports for files submitted prior to March 27, 2013, please contact CSSC Operations at (877) 534-2772, with your file information, for assistance.

Submission Frequency

- The minimum frequency of submission is based on enrollment size.
- MAOs and other entities may submit data as often as daily.

Number of Medicare Enrollees	Minimum Submission Frequency
Greater than 100,000	Weekly
50,000 – 100,000	Bi-weekly
Less than 50,000	Monthly

Note: CMS will use the February 2013 Health Plan Management System (HPMS) contract enrollment data to determine submission frequency requirements for each MAO or other entity.

Timely Filing Deadline

- MAOs and other entities must submit encounters to the EDS according to the timely filing guidance:

Submission Type	Timely Filing Deadline
Full Encounters	13 months from the Date of Service (DOS) <ul style="list-style-type: none">Institutional – “Through” DOSProfessional – Service Line DOS
Adjustment Encounter*	30 days after the adjudication date
Chart Review Encounters	Within 25 months of the data collection period

*Adjustment (correct/replace or void/delete) encounters should be submitted within 13 months from the DOS; **or** 30 days after the adjudication date if the adjustment was received beyond the 13-month timely filing period.

EDS Updates

EDS

Known Issues

EDPS Known Issues

- One (1) Known Issue is currently resolved:

Edit #	Edit Description	Resolution Date
22225	Missing Provider Specific Record	3/29/2013

- Two (2) Known Issues are currently pending resolution:

Edit #	Edit Description	Target Resolution Date
03102	Provider Type or Specialty Not Allowed to Bill Procedure • <i>Final resolution will cause Edit 03102 to reflect a "Reject" status.</i>	TBD
22220	DOS Prior to Provider Effective Date	TBD

EDS Edit(s)

Edit 00265 – Prevention Strategy

- In order to prevent edit 00265 ‘Correct/Replace or Void ICN Not in EODS’, when submitting encounters with a claim frequency code of ‘7’ for correct/replace or ‘8’ for void/delete:
 - Verify the accepted ICN is present and is appropriate for the encounter type (original or previously adjusted encounter).

Edit 98325 – Service Line(s) Duplicated

- CMS is currently evaluating potential enhancements to the EDS duplicate logic validation for edit 98325.
- MAOs and other entities that have submitted questions regarding this edit will receive responses once the evaluation is complete and determinations are made.
- CMS will provide additional guidance to the industry, if required.

EDS Operational Error Prevention Strategies

Adjustment Encounter

Scenario #1

Scenario

1. Dr. Jones submits a claim to Happy Health.
2. Happy Health submits an original encounter to the EDFES.
3. Happy Health receives a 999 reject acknowledgement report for the original encounter.
4. Dr. Jones submits a corrected claim to Happy Health.
5. Happy Health resubmits the encounter as the original.

Issue

Happy Health submitted invalid information from Dr. Jones which resulted in a rejected encounter.

Adjustment Encounters

Scenario #1 (Cont'd)

Providers
Professional or Institutional

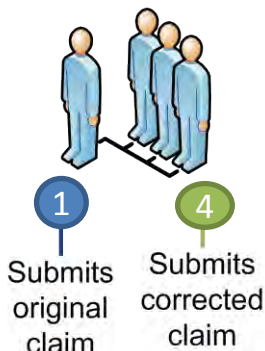

MAOs and Other Entities
(x12 Submitter)

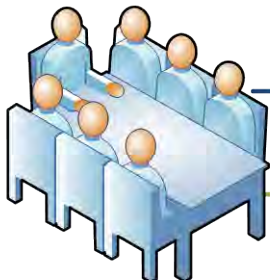

Encounter Data Front-End System (EDFES)



Error Checking /Syntax/Structure

Acknowledgement Reports
TA1
999
277CA

Original encounter rejected



Adjustment Encounter Scenario #2

Scenario

1. Dr. Jones submits a claim to Happy Health.
2. Two days later, Dr. Jones submits two (2) subsequent adjustments to Happy Health for the claim.

Issue

Happy Health is unsure how to submit all three (3) encounters to the EDFES.

Adjustment Encounters

Scenario #2 (cont'd)

Encounter Data

User

Group

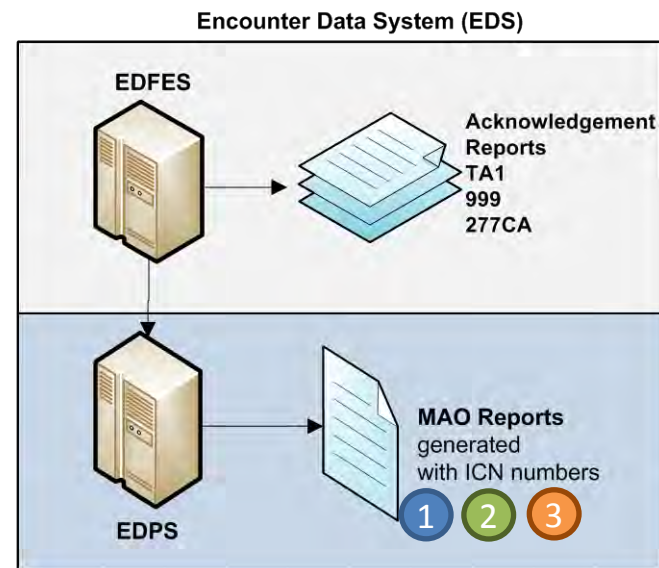
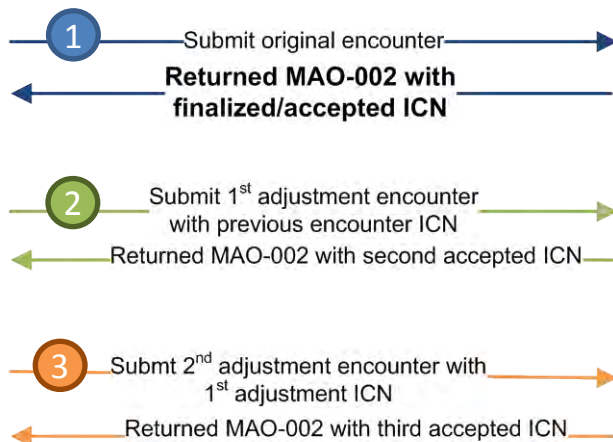
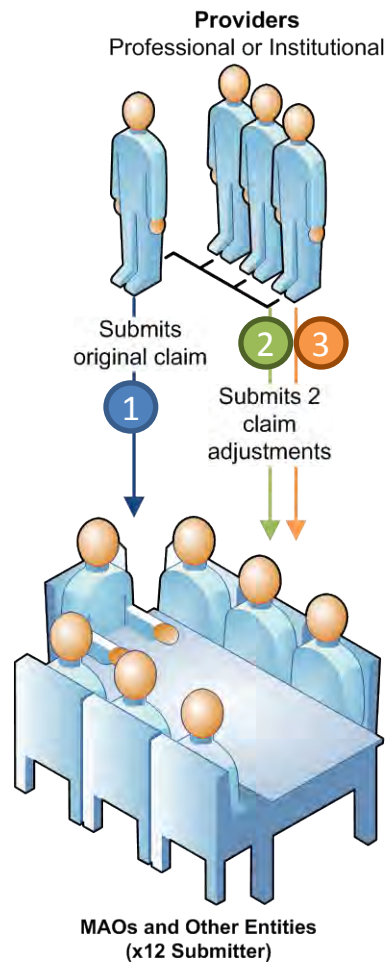

Thursday, April 4, 2013
3:00 P.M. – 4:00 P.M. ET

Edit 02125 Beneficiary Date of Birth Mismatch Scenario #3

Scenario

- Happy Health submits an encounter to the EDPS.
- The EDPS rejects the encounter with Edit 02125 – ‘Beneficiary DOB Mismatch’.
- Happy Health receives an MAO-002 Report with Edit 02125 – ‘Beneficiary DOB Mismatch’.

Issue

Happy Health must determine why the beneficiary’s DOB on the encounter does not match the DOB in the EDPS member database.

PACE Services



Program of All-Inclusive Care for the Elderly (PACE) Services

- Offered by non-profit public or private organizations.
- Provide all-inclusive acute and long term care services to frail elderly Medicaid and Medicare enrollees
 - who are at least 55 years old
 - require a nursing facility level of care
 - live in an area served by a PACE organization

PACE Services

- PACE organizations are required to submit encounter data using the HIPAA compliant 5010 format.
- The use of HCFA 1500 or UB04 paper claims will not be acceptable for encounter data.
- EDI support software applications can be used to convert paper claims to electronic format.
 - PC-ACE Pro32 Software is available to assist organizations with the transfer of paper claims data to the 5010 format.
 - [http://www.palmettogba.com/Palmetto/Providers.nsf/files/EDI_PCACE_Pro32_Man.pdf/\\$File/EDI_PCACE_Pro32_Man.pdf](http://www.palmettogba.com/Palmetto/Providers.nsf/files/EDI_PCACE_Pro32_Man.pdf/$File/EDI_PCACE_Pro32_Man.pdf)

PACE Certification Timeline

- The PACE certification deadline was February 28, 2013 for MAOs and other entities effective prior to 2013.
- PACE organizations are required to begin submitting 2013 DOS production data once they have achieved end-to-end certification. Production data includes:
 - Institutional, Professional, and DME encounters for services for which claims are generated or for which encounter data is otherwise available.
- PACE organizations are not currently required to submit encounters for services provided to PACE participants by PACE staff.
- CMS will continue discussions regarding submission of PACE services provided to PACE participants by PACE staff.

PACE Third Party Submitters

- Third Party Submitters (TPS) must submit an EDS Electronic Data Interchange (EDI) agreement to CSSC to submit solely on behalf of PACE organizations.
- PACE only TPS may submit the PACE specific test cases for end-to-end certification.
- PACE only TPS are not required to recertify if they contract with additional PACE organizations.
- If the PACE only TPS opts to submit for non-PACE organizations, they will be required to recertify using the full set of test cases.
- PACE test cases are located on CSSC website at:
 - <http://www.csscooperations.com/internet/cssc3.nsf/docsCat/CSSC~CSSC%20operations~Encounter%20Data~ED%20Testing?open&expand=1&navmenu=Encounter^Data>

Questions & Answers

Guidance for New 2013 MAOs and Other Entities

Error Reconciliation for Acknowledgment Reports

TA1 Error Reconciliation

1. Locate the TA1 Acknowledgment Report and the Segment Identifier

2. Locate the Interchange Acknowledgement Code = 'R'

3. Locate error from the Interchange note code

4. Identify the appropriate edit spread sheet (837-I and 837-P)

5. Locate the Interchange note code in the CEM Edits spreadsheet

6. Access the 837 file with the Interchange control number

7. Correct the information and resubmit the 837 file

TA1 Error Reconciliation (cont'd)

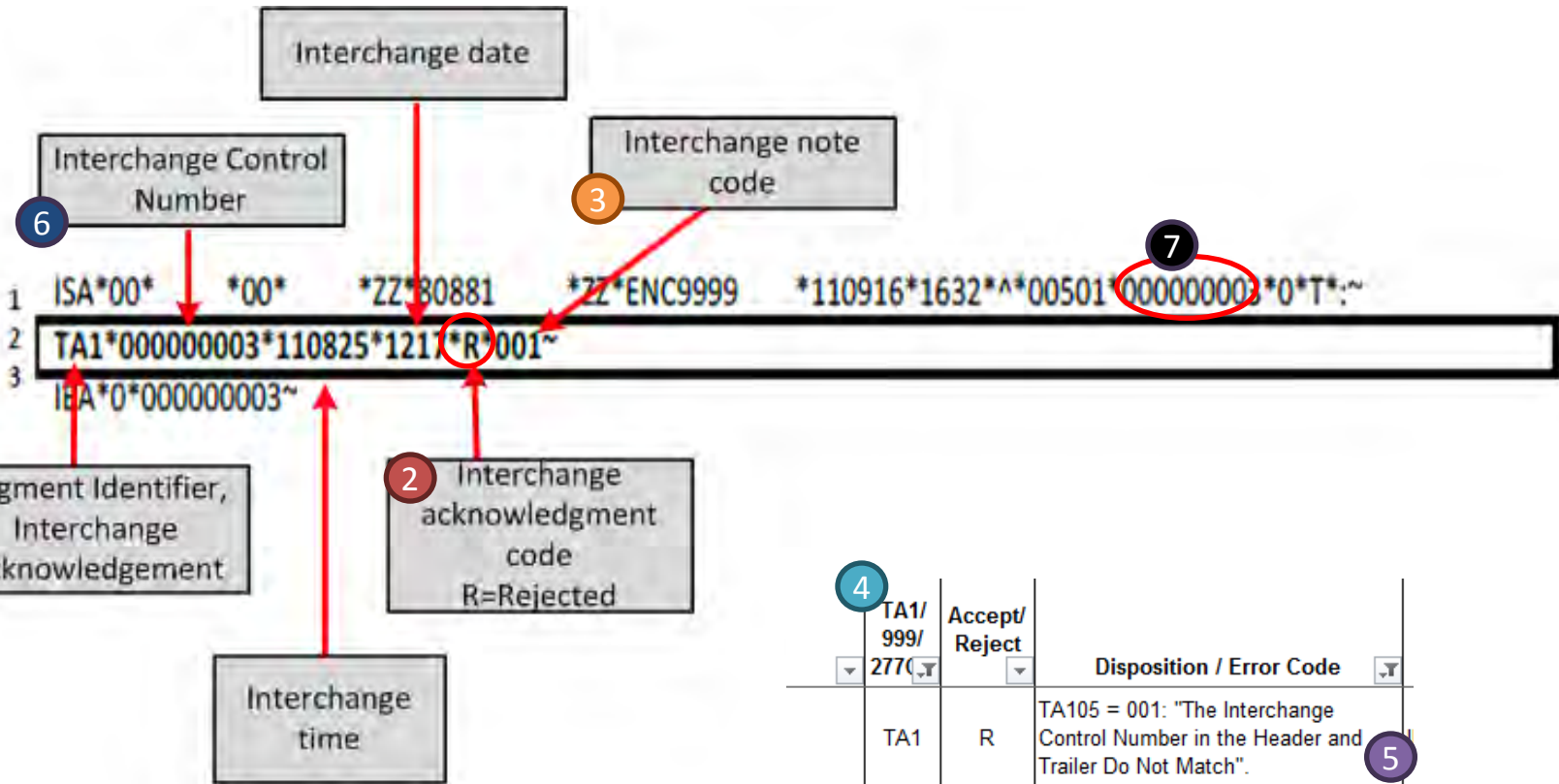

4	TA1/999/277C	Accept/Reject	Disposition / Error Code
	TA1	R	TA105 = 001: "The Interchange Control Number in the Header and Trailer Do Not Match". 5
	TA1	R	TA105 = 001: "The Interchange Control Number in the Header and Trailer Do Not Match".

999 Error Reconciliation

1. Locate the Response Header

2. Locate errors for transaction set

3. Access the CMS Edit Spreadsheet and WPC 999 TR3

4. Look up the error(s) from the IK3 segment

5. Correct error(s) from the IK3 segment description using Transaction Set Control Number and Loop Identifiers

6. After all encounters in the transaction set are corrected, resubmit the transaction set

999 Error Reconciliation (cont'd)

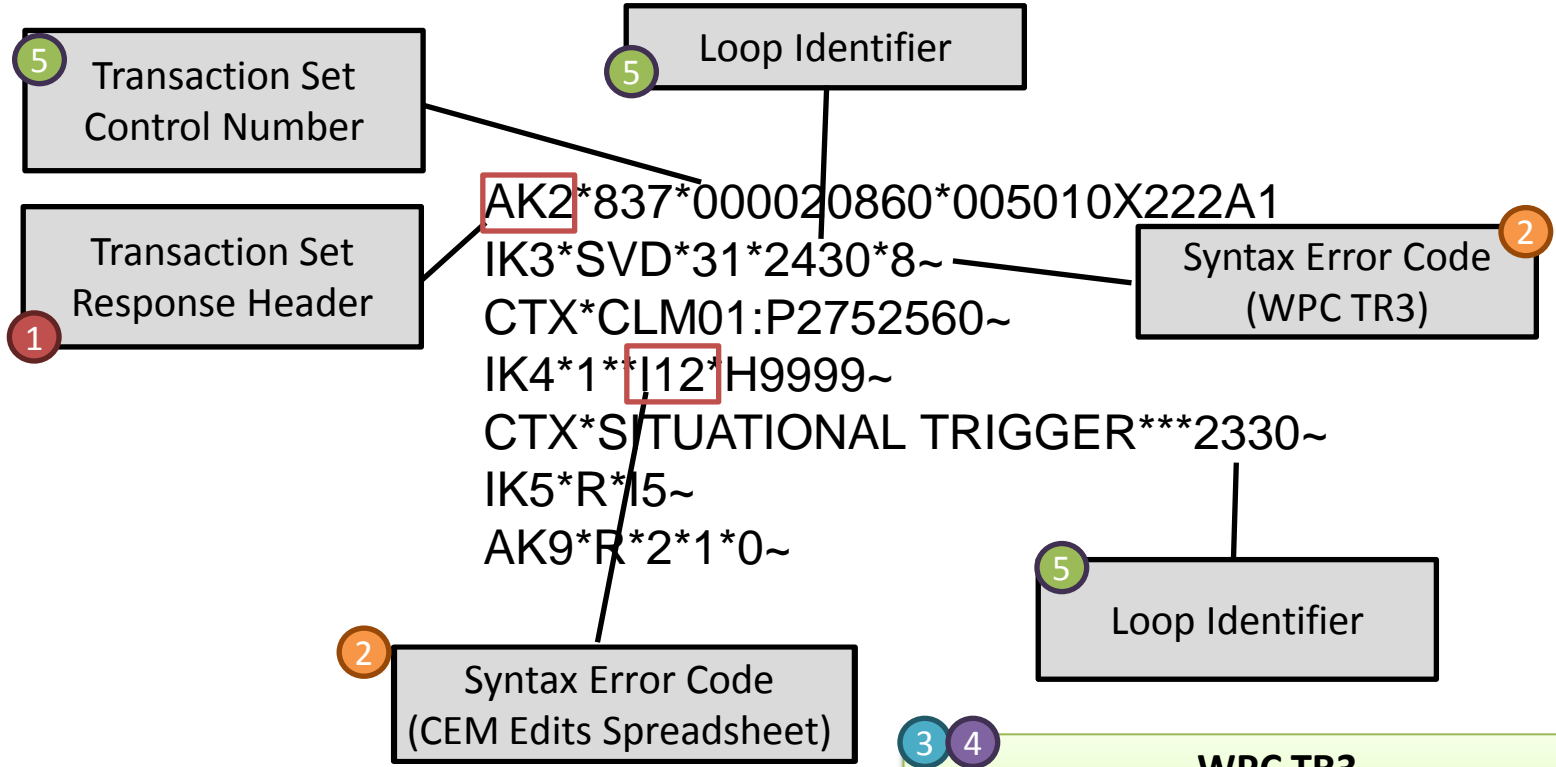

WPC TR3
 Error IK304 = 8 was found in the 999 TR3 = "Segment has data element errors"

3	837I Edit Reference	TAI/999/277C A	Accept/Reject	Disposition / Error Code	4	Proposed 5010 Edits	Misc. Notes
	X223.476.2430.SVD.010	999	R	IK304 = 5: "Segment Exceeds Maximum Use"		Only one iteration of 2430.SVD is allowed.	
	X223.476.2430.SVD01.010	999	R	IK403 = 1: "Required Data Element Missing"		2430.SVD01 must be present.	
	X223.476.2430.SVD01.020	999	R	IK403 = 112: "Implementation Pattern Match Failure"		2430.SVD01 must = 2330E.NM109 (for the same paper).	



EDS Companion Guides Updates

EDS Companion Guides

- The March Release of the EDS Companion Guides is posted on the CSSC Operations website:
<http://www.csscoperations.com/internet/cssc3.nsf/docsCat/CSSC~CSSC%20Operations~Encounter%20Data~Companion%20Guides?open&expand=1&navmenu=Encounter^Data>
- March Release Updates:
 - EDPS Enhancement Implementation Updates
 - 837-Institutional File Limitations
 - EDPS Edits Prevention and Resolution Strategies – Phase III
 - Proxy Data Reason Codes Operational Guidance

EDS Implementation Next Steps

EDS Implementation Next Steps

ED Materials / Information	Target Date
EDS User Group	April 18, 2013
Companion Guide	April 25, 2013
Getting Started Webinar Series	May 2013
EDS Newsletter	May 2013

Questions & Answers

Resources

Resources

Resource	Resource Link
CEM/CEDI Technical Reporting Formats	http://www.cms.gov/MFFS5010D0/20_TechnicalDocumentation.asp
Centers for Medicare & Medicaid Services (CMS)	http://www.cms.gov/
CSSC Operations	http://www.csscooperations.com csscooperations@palmettogba.com
EDS Inbox	eds@ardx.net
Technical Assistance Registration Service Center (TARSC)	http://www.tarsc.info/
X12 Version 5010 Standards	https://www.cms.gov/Regulations-and-Guidance/HIPAA-Administrative-Simplification/Versions5010andD0/index.html?redirect=/Versions5010andD0/
Washington Publishing Company	http://www.wpc-edi.com/content/view/817/1

Closing Remarks