



- Universal American
- Universal Health Care, Inc.
- WellCare
- WellPoint

The primary purpose of the Encounter Data Work Groups is to provide a forum for communication between the Centers for Medicare & Medicaid Services (CMS), Medicare Advantage Organizations (MAOs), and Third Party Submitters to determine and discuss issues while creating possible solutions for final implementation of Encounter Data.

The goals for this series of sessions for Chart Reviews and Data Submission for Chart Audits include:

- Identification of data collection methods for chart review,
- Submission of chart review data using the required 5010 format, and
- Determination of best practices for validating data.

The expected discussion topics for this session were:

- The timely filing rule and its application in the submission of retrospective chart review data.
- Process for submission of adjustment data.
- Additional 5010 segment and loop identifiers to the PWK01 segment for documentation of supplemental or chart review data.
- Validation processes for collected encounter data elements through increased chart reviews and visits to provider offices.
- Best practices for utilizing transaction reports, management reports, and remittance advice for chart review and chart audit data.
- Required data elements on reports that reflect chart review activity.

The second session of the Chart Reviews and Data Submission for Chart Audits Work Group focused on processes for MA submission of adjustments, corrections, and deletions, and identification of current contractual specifications regarding the timely filing rule, as well as timeframe recommendations for timely filing requirements of encounter and chart review data submission.

Introduction

Before opening the forum for discussion, a review of the materials sent to plans prior to the work group was provided. Summary information regarding data collected from the first Chart Reviews and Data Submission for Chart Audits session was provided as well as process updates based on policy decisions made since the first work group session. The following were main points discussed during the introduction and review of the work group materials and past discussions regarding chart review data:

- Participants of the previous Chart Reviews and Data Submission for Chart Audits work group reported:
 - The volume of data obtained through chart review processes ranges from less than 5% to 75%, and
 - The amount of data obtained through chart reviews impacting payment ranges from less than 5% to 20%.



- Three options for submission of chart review data to CMS were discussed during the last Work Group:
 - Utilization of the PW01 segment report type code,
 - Utilization of the CAS segment, or
 - Development of a separate format for submission of chart review data.

Overview of the Transmission File

Figure 1 illustrates the structure of a transmission file including the interchange (ISA—IEA), functional group (GS—GE), and claim levels (ST—SE). At the claim level (ST-SE), the current system limitation recommendations are to accept no more than 5000 CLM segments. CMS is currently evaluating system limitations for the Encounter Data System and is considering using a threshold of 2500 CLM segments. There is no recommended limit currently for the number of ST-SE transactions in the GS-GE or ISA-IES envelopes.

Figure 1: Transmission File structure

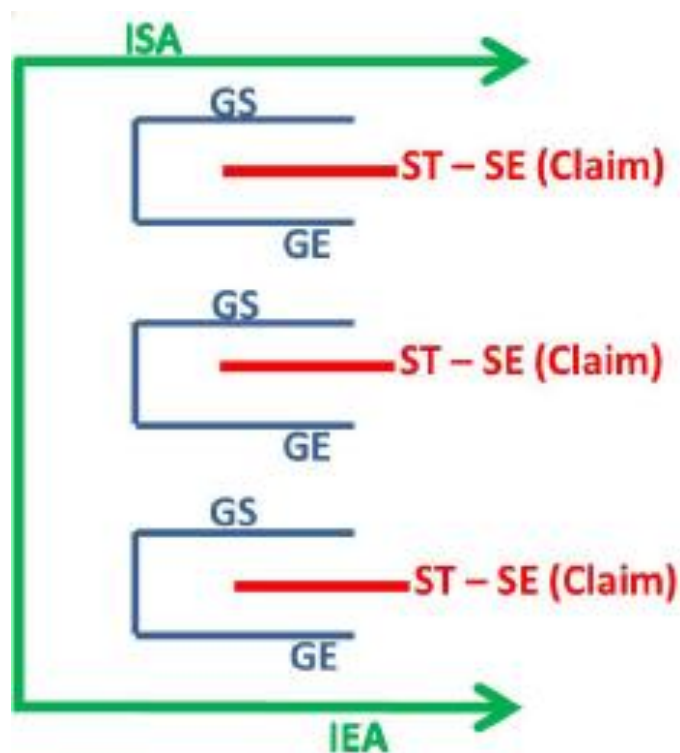

Identification of Chart Review Data on the 5010

CMS will be collecting chart review data as part of the encounter data process. The PWK segment report type code within the 2300 loop of the 5010 format will be used to identify chart review data submissions for collection of encounter data. Figure 2 displays the chart review submission process in regards to required data elements to be populated for the 5010.



- The PWK01 data element should be populated with a value of '09.' Currently, the value '09' is defined as *Progress Reports*. However, for the purposes of encounter data, this value will be redefined to identify *Chart Review* data submitted by MAOs.

Figure 2: Chart Review Submission

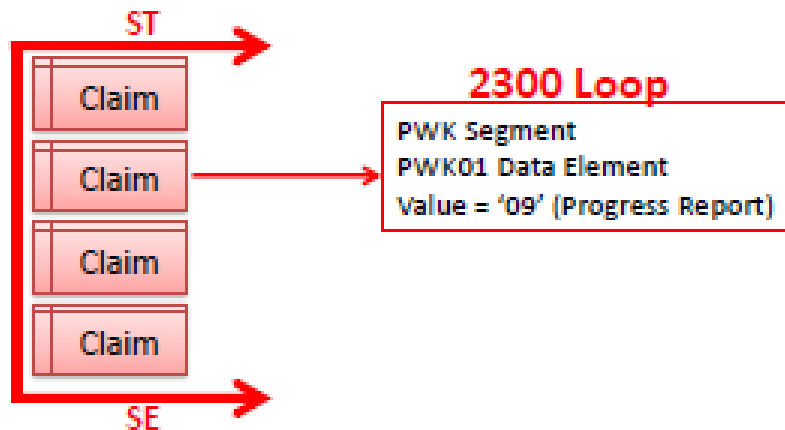

Linking Chart Review Data to the Original Encounter

In order to link the chart review data to the original encounter, when available, MAOs must use the ICN that CMS provides on the 277CA transaction report returned to plans. The beneficiary must have a claim on record. The ICN is located in the 277CA in loop 2200D, REF01 (Reference Identification Qualifier) with a value of '1k' (Payer's Claim Number) and REF02 (Reference Identification) with a value 'Claim Number' (Payer Claim Control Number).

If there is no date of service for the diagnoses obtained from the chart review and there is no original encounter to link data then:

- The chart review data should be submitted with the PWK01 segment populated to flag it as chart review data, and
- At a minimum, the beneficiaries' information, diagnosis codes, diagnoses, NPI, and the date of service must be added to the claim from information available in the medical record during the chart review process. More details regarding required elements will be discussed during the next Chart Review Work Group.

Submission of Adjustment Data

Adjustment data is submitted at the claim level within the ST—SE transaction envelope of the transmission file. Figure 3 illustrates the 5010 population requirements for submitting adjustment data. The adjustment claim submitted will supersede the original claim therefore the adjustment claim must be submitted as the finalized claim

- The REF segment will identify the Claim Control Number. REF01 data element of the 2300 loop must be populated with a value of 'F8' (Original Reference Number). REF02 data element must be populated with the Claim Number received on the 277CA.



- The CAS segment (CAS01 data element) within the 2300 loop of the 5010 will be used to submit adjustment data. Three value options will be redefined so that plans may submit adjustment data using the CAS segment:
 - CR=Correction
 - This overwrites the submitted encounter and will replace any previously submitted data.
 - An adjustment indicator ('CR') within the CAS segment can only be used within the 2300 level loop not the 2400 level loop. Line level adjustments cannot be processed.
 - CO=Add only
 - The 'CO' option will be used for MA plans adding more than the allowable number of diagnoses on a professional (837-P) or institutional (837-I) encounter (12 diagnoses are allowed on the 837-P and 25 diagnoses are allowed on the 837-I).
 - OA=Deletion
 - This allows a plan to delete previously submitted encounter data.
 - A deletion indicator ('OA') is submitted to delete an entire claim. Line level deletions cannot be processed.
- The CLM segment (CLM05-03 data element) within the 2300 loop of the 5010 will be populated with value '07' for replacing or appending a prior claim. This corresponds to the CAS01 values of 'CR' or 'CO.' Or the CLM05-03 data element could be populated with a value '08' for deleting a prior claim. This corresponds to the CAS01 value of 'OA.'

Figure 3: Submitting Adjustment Data

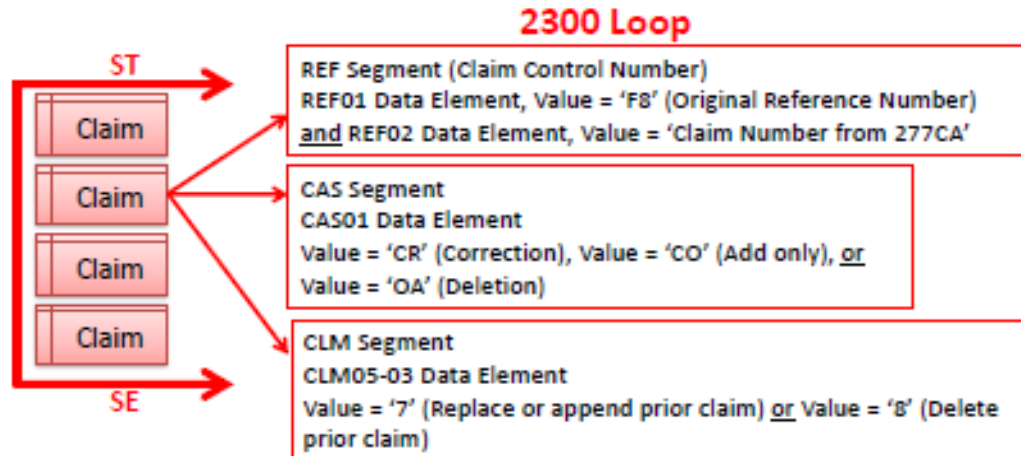

Encounter Data Adjustment Processes and Provider Confusion

Adjustment data must be re-submitted with the correct original claims data. Some participants reported that with the current system, automated messages are sent to providers upon modification of claims data related to reimbursement within internal legacy systems. Submission of additional finalized adjustment claims for encounter data rather than submission of solely the data being modified (added, deleted, changed, etc.) may cause provider confusion due to automation of messages sent. Plans would need to program systems to eliminate the automated responses to providers.



5010 Acknowledgement Reports

For encounter data submission, edits will be applied on three levels during the Front-end processing:

- The TA1 (Translator Edits) performs transmission file X12 interchange level/ISA – IEA edits,
- The 999 (Translator, IG edits) performs X12 functional group/GS - GE validation editing, and
- The 277CA (CEM, CEDI edits) performs claim level/ ST- SE Medicare specific edits, and CMS-selected IG edits that validate data content.

Therefore, MAOs will receive the following front-end reports from the EDFES (**Figure 4** illustrates the types of return reports that will be received following encounter data submission and what level of the transmission file they represent):

- A TA1 report will be received when an error occurs within the interchange ISA/IEA functional groups of the transmission file,
- A 999R will be received when an encounter is rejected due to a fatal error occurring at the transaction set or batch level (ST—SE) of the transmission file,
- The 999E will be received if an encounter passes the 999 edits at the transaction set level and is accepted for further processing through the Encounter Data System (EDS), and
- The 277CA will be received for each claim file and will show whether a claim was rejected, as well as the reason for rejection.

Figure 4: 5010 Acknowledgement Reports

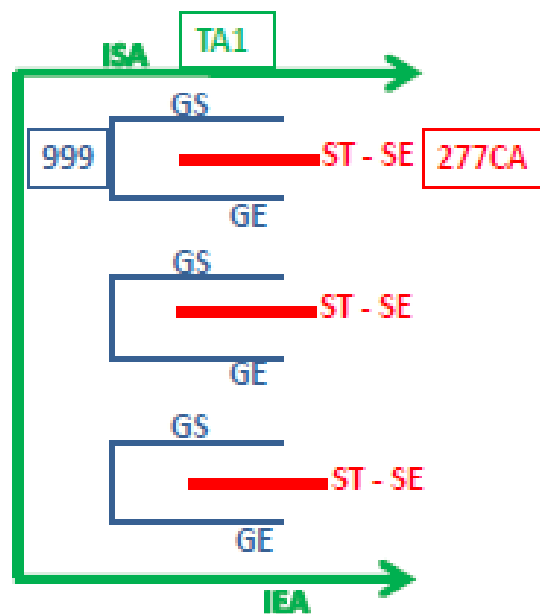

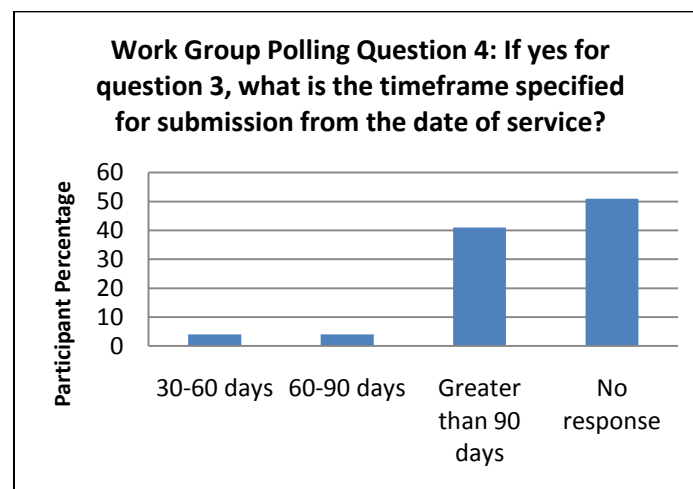
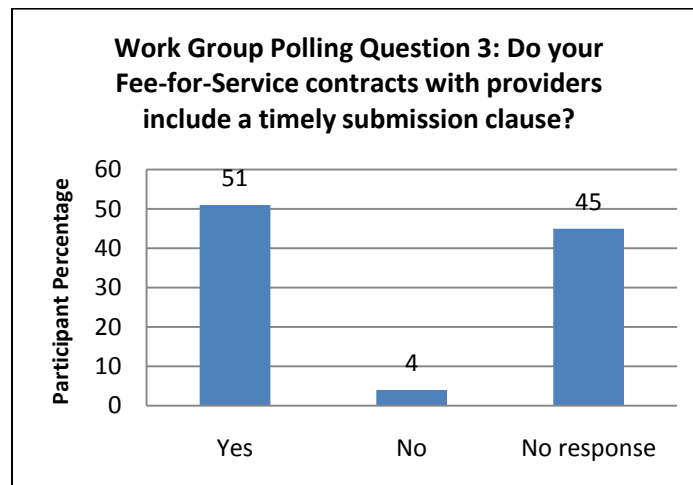
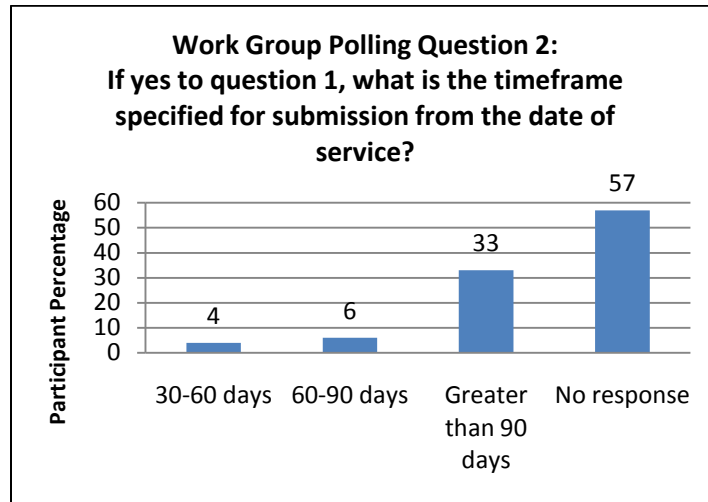



Current Timely Filing Specifications for Contracted and Non-Contracted Providers

For contracted providers, participants reported timely filing specifications ranging from 4 to 12 months after the date of service. Participants reported that out of network providers have unlimited time to submit claims data.

Time Limitations for Chart Review Processes

Multiple participants of the work group reported not having a timely filing rule for retrospective chart reviews and following the sweep date schedule. One participant reported conducting chart reviews on an annual basis.

Issues Identified:

Timely Filing Constraints for Data Submission

Participants reported needing additional time for submission of encounter data and the chart review processes. Currently, many providers are allowed 12 months from the date of service to submit claims data. Participants stated that many providers do not submit data until the last month and additional time, in these cases, would be needed to process and submit data and conduct necessary chart reviews.

One participant reported conducting provider audits mimicking the RADV audit schedule and that additional time would be needed to process necessary deletions based on the audit results.

Participants' Recommendations/Suggestions

- Participants suggested that the same amount of time as current requirements be allotted for chart reviews and submission of provider audit deletions.

Additional Questions Addressed Throughout the Work Group

The following are additional questions discussed by participants during the Chart Reviews and Data Submission for Chart Audits Work Group.

Questions asked by Participants

Q1: Do capitated and Fee-for-Service claims have to be submitted in separate batches?

A1: No, MA plans may submit capitated and FFS claims within the same batch.

Q2: Must all fields in each 'GS' functional group be populated prior to submitting claim level information ('ST' level)?

A2: Yes.

Q3: Will the notes from this work group session be available for review?

A3: Yes, upon the conclusion of each workgroup and industry update session, summary notes, and Q&As derived from each session are posted to the www.tarsc.info website for the entire industry to view.



Q4: When will the companion guide be released?

A4: Information that will essentially become pages of the companion guide will be released as decisions are made. The complete guide will be released Summer of 2011.

Q5: Will filtering edits be turned on for the Encounter Data System Front End (EDFES) testing from March through June?

A5: All edits which are required for translator and Implementation Guide editing will remain on. All edits impacting formatting in CEM will also remain on.

Q6: Can a diagnosis be rejected for pricing purposes but accepted for risk adjustment?

A6: Diagnosis would need to be valid and pass all edits before the data will be finalized and stored.

Q7: Will the same chart review processes be used for home care and PPS?

A7: This is still under evaluation.

Q8: Is the Chart Review and Data Submission for Chart Audits work group series a good place for discussion of supplemental data submission?

A8: Yes. Please send work group discussion topics to the eds@ardx.net mailbox.

Q9: Will encounters still have the year-end sweeps every two years with the 12 month submission timeline on all encounters?

A9: This policy is under development.

Q10: If there is a lag for encounter data that comes in and chart review data needs to be submitted, how do we submit?

A10: The timeline for this is under development.

Q11: If a diagnosis was submitted as a result of a chart review using the PWK segment, and later reviewed and identified to be deleted, how should this be handled?

A11: The CAS segment should indicate CR to overwrite the original claim and the CLM segment should be populated with an "OA."

Q12: Why wouldn't the '09' values be excluded from the utilization measurements? Chart reviews are for diagnosis code accuracy only.

A12: The purpose of collecting encounter data is to be able to collect all data elements needed for pricing, as this will help achieve accurate estimation of the cost of care in the MA population.

Q13: In a RADV, will CPT levels also be considered as proper documentation elements when audits are conducted?

A13: The RADV policies are currently under review.

Q14: In regards to data elements that will be reflected in the reports for chart review activity, will they include similar element as the RAPS reports today?

A14: This is currently being evaluated by CMS. If plans have recommendations or suggestions regarding ideal format of the reports, please submit these to eds@ardx.net.



Key Conclusions and Recommendations for Encounter Data Editing and Reporting Work Group

Based on the information discussed in the Chart Reviews and Data Submission for Chart Audits Work Group held on February 16, 2011, the following recommendations were provided to ensure successful implementation of the collection of encounter data.

Recommendations

- CMS suggested plans utilize the Washington Publishing Company (WPC) resource (<http://www.wpc-edi.com/content/view/817/1>) for systems specifications to assist with transitioning to data collection through the 5010 837 format. Chart review data must be submitted in the 5010 837 format as does regular encounter data submissions.
- For submission of bundled services, participants reported that adjustments should be sent with the same amount of lines as the original encounter submission.
- The current adjustment process outlined for encounter data submission should be used (adjustment claims submitted supersede the original submission).

Action Items and information needed from Participants

The next Encounter Data Work Group for Chart Reviews and Data Submission for Chart Audits will be held on April 6, 2011. The next Industry Update will be held on March 16, 2011.

Work group participants should send the following items to eds@ardx.net:

- Recommendations and expectations for data elements of chart review reporting.
- Any additional topics for discussion during the next work group for Chart Reviews and Data Submission of Chart Audits.
- Any further questions related to encounter data.